

Multifunction transmitter C 310

KEY POINTS

- 2 inputs for interchangeable probes
- 1 location for interchangeable SPI-2 board
- Simultaneous display of 1 to 4 parameters
- Trend indicator
- 4 visual (dual-color LEDs) and audible alarms
- 2 analogue outputs (4 wires) 0/5-10 V or 0/4-20 mA, 2 additional outputs (optional)
- 4-relay board (optional)
- 24 Vdc/Vac or 115/230 Vac power supply
- Outputs diagnostic
- Ethernet communication (optional)
- MODBUS network RS485 system (optional)
- ABS housing with stainless steel front, IP65, with or without backlit graphic display
- "¼ turn" system mounting with wall-mount plate



FEATURES OF THE HOUSING

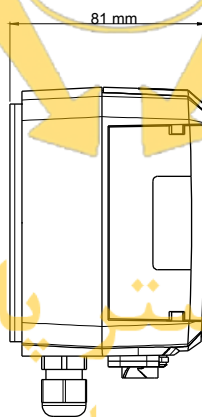
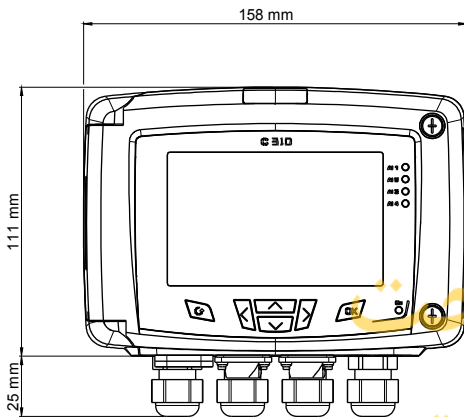

Material : ABS V0 as per UL94

Protection : IP65

Display : Graphic from 1 to 4 lines, 240 x 128 px ;
Size : 86 x 51 mm,
Backlit

Height of digits : Values : 10 mm ; Units : 5 mm

Cable gland : in polyamide for cables Ø 9 mm maximum

Weight : 700 g

PART NUMBERS

- **C310-BO** : multifunction transmitter, 24 Vac/Vdc power supply, with display
- **C310-HO** : multifunction transmitter, 115-230 Vac power supply, with display
- **C310-BN** : multifunction transmitter, 24 Vac/Vdc power supply, without display
- **C310-HN** : multifunction transmitter, 115-230 Vac power supply, without display

TECHNICAL SPECIFICATIONS

Power supply	24 Vac / Vdc $\pm 10\%$ 115 Vac to 230 Vac $\pm 10\%$, 50-60 Hz
Outputs	2 x 0/4-20 mA or 2 x 0-5/10 V (4 wires) or 4 x 0/4-20 mA or 4 x 0-5/10 V (optional) Maximum load : 500 Ohms (0/4-20 mA) / Minimum load : 1 K Ohms (0-5/10 V)
Galvanic isolation	Inputs (power supply) and outputs (on 115 Vac/230 Vac models) Outputs (on 24 Vac/Vdc models)
Consumption	10 W
Relays	4 RCR relays 5 A / 230 V (optional)
Conformity	CEM 2004/108/CE and NF EN 61010-1 directives
Electrical connections	Screw terminal block for cables from 0.05 to 2.5 mm ² or from 30 to 14 AWG
RS485 communication	Digital : Modbus RTU protocol, configurable communication speed from 2400 to 115200 Bauds (optional)
Ethernet communication	Ethernet communication module allowing transmission, monitoring and maintenance of transmitters via an Ethernet network in 10 BASE-T and 100 BASE-TX LAN/WAN supporting TCP/IP protocol (optional)

TECHNICAL SPECIFICATIONS

Environment and type of fluid	Air and neutral gases
Operating/Storage temperature	From -10 to +50 °C / From -10 to +70 °C

RELAYS AND ALARMS

The C 310 transmitter has 4 independent and configurable alarms : these are visual and audible alarms and it is possible to couple them with 4 relays (optional).

Available settings :

- Selection of the parameter (pressure, air velocity, temperature,...)
- Time-delays duration from 0 to 600 s
- Alarm action : rising edge, falling edge, monitoring or state of the transmitter
- Operating mode of the relays : negative or positive safety (optional)
- Activation of the audible alarm (buzzer) that can be acknowledged by the front keypad (optional)

CONNECTIONS

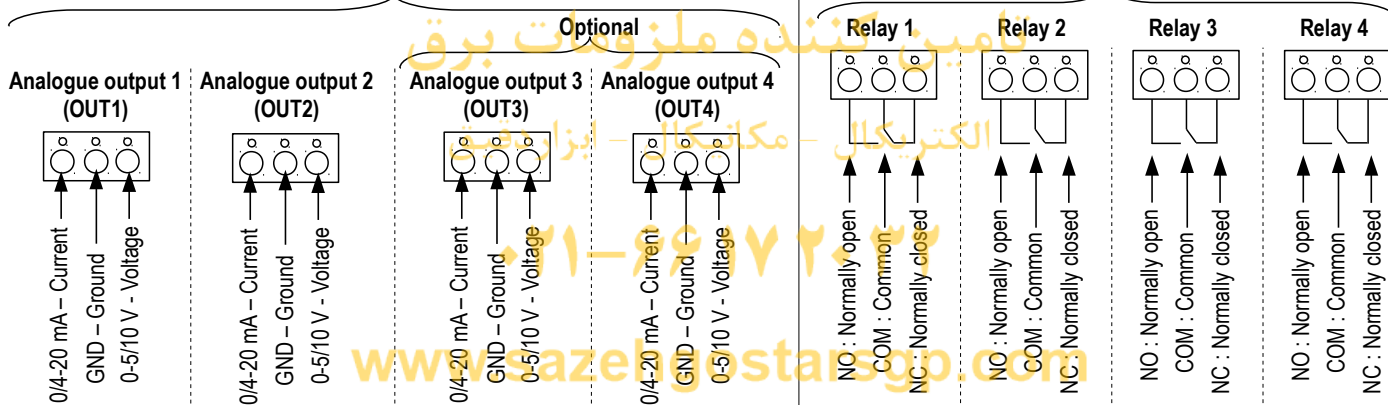
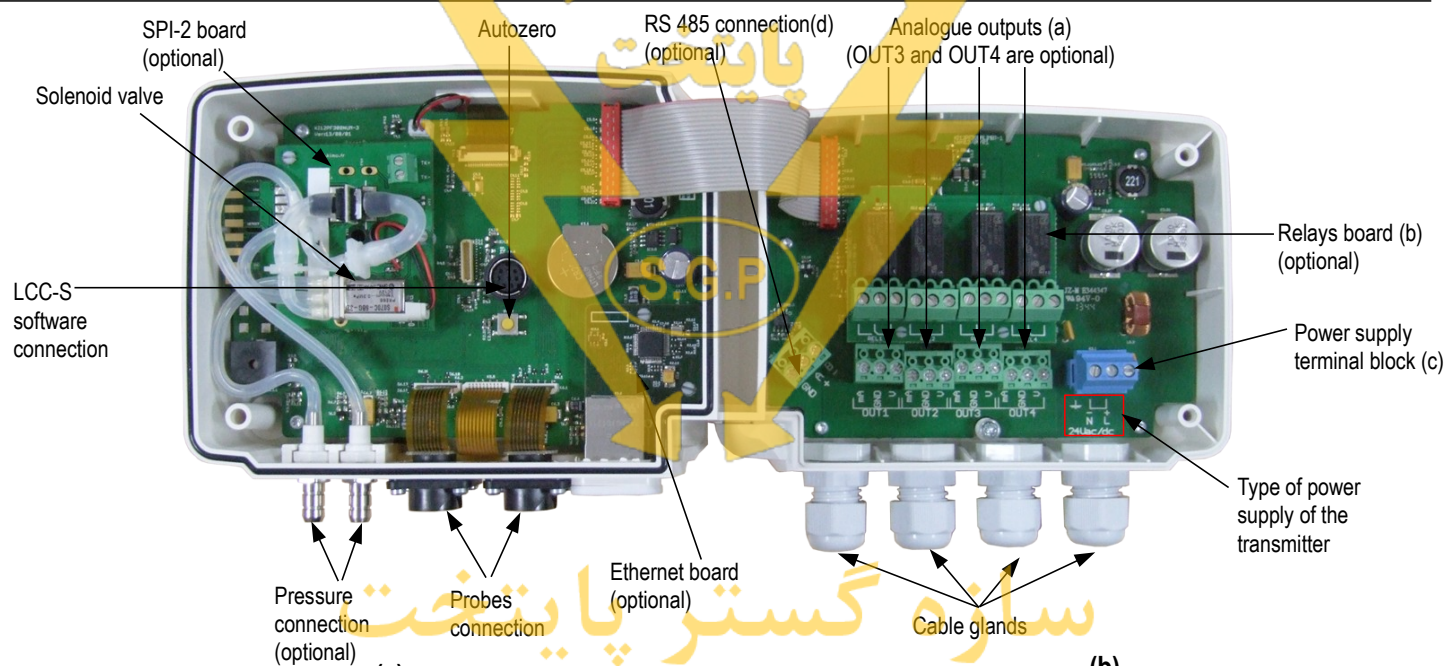

(c) For 24 Vdc/Vac power supply models :

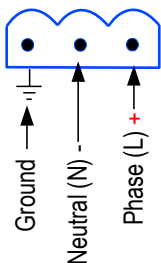

or For 115 Vac or 230 Vac power supply models :

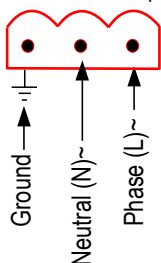

(d)

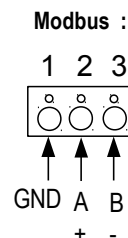



This connection must be made by a qualified technician. Whilst making the connection, the transmitter must not be energized.

> For 24 Vdc power supply models :

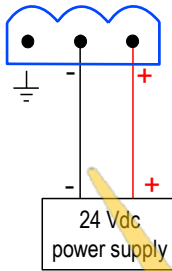

> For 115 Vac or 230 Vac power supply models:

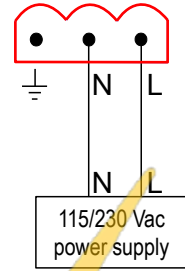

> For 24 Vac power supply models :

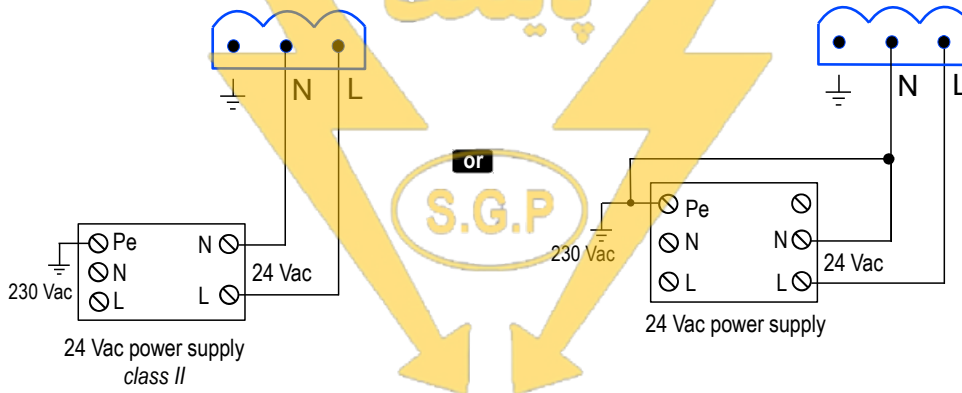

> 0/4-20 mA current output connection :

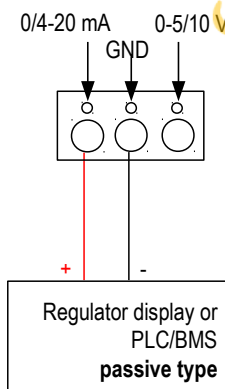

> 0-5/10 V voltage output connection :

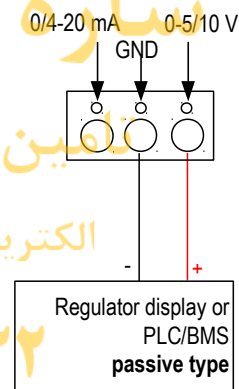

RS 485 MODBUS PROTOCOL (optional)

Class 310 transmitters can be linked in one network operating on a RS485 home bus. The RS 485 digital communication is a 2-wire network, on which the transmitters are connected in parallel. They are connected to a PLC/BMS via the RTU Modbus communication system. Since the C310 can be configured with the keypad, the MODBUS enables remote configuration, to measure 1 or 2 parameters or to see the status of the alarms...

ETHERNET BOARD (optional)

An Ethernet board can put put on a C310 transmitter allowing for each transmitter to have a specific configurable IP address. So the user can remotely interrogate the transmitter, retrieve data, modify the configuration,... It is also possible to integrate C310 transmitters into a computer network via the RJ45 connection located at the bottom of the transmitter.

CONFIGURATION

Class 310 transmitters allows you to set all the parameters managed by the transmitter : units, measuring ranges, alarms, outputs, channels... via the different methods shown below :

- > **Via keypad**, only on models with display. A code-locking system for keypad guarantees the security of the installation. See configuration manual.
- > **Via software (optional)** : simple and user-friendly. See LCC-S user manual.
- > **Via Modbus (optional)** : configuration of all parameters from your PC, via the supervision or data acquisition software.
- > **Via Ethernet (optional)** : configuration of all parameters from your PC, via the supervision or data acquisition software.

MOUNTING

To install the transmitter on a wall, fix the stainless steel plate to the wall (drilling : $\varnothing 8$ mm, screws and wall-plugs supplied). Insert the transmitter on the plate (see A on the drawing below) by aligning it at 30° . Rotate the housing in clockwise direction until you heard a "click" which confirms that the transmitter is correctly installed. Open the housing, lock the clamping system of the housing on the plate with the screw (see photo below). To remove the transmitter from the fixing plate, do not forget to remove this screw.

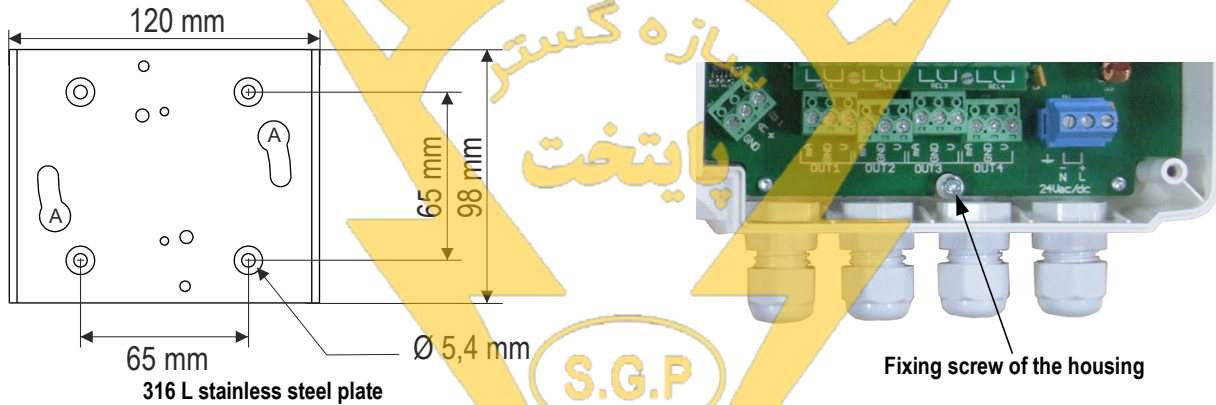

CALIBRATION

Adjusting and calibration on site : the professional configuration interface, with a dynamic pressure calibration bench, allows you to adjust and calibrate your transmitters directly on site or in laboratories.

Outputs diagnostics : with this function, you can check with a multimeter (or on a regulator/display, or on a PLC/BMS) if the transmitter outputs work properly. The transmitter generates a voltage of 0 V, 5 V and 10 V or a current of 0 mA, 4 mA, 12 mA and 20 mA

Certificate : transmitters are supplied with an individual adjusting certificate and can be supplied with a calibration certificate as an option.

MAINTENANCE

Avoid aggressive solvents. When cleaning rooms or ducts with products containing formol, protect the the transmitter.

OPTIONS

- **LCC-S** : configuration software with USB cable.
- **SQR/3 function** : (square root extraction) function for the calculation of air velocity and airflow.
- **RS5** : RS 485 Protocol Modbus digital output
- **O2S** : 2 additional analogue output
- **C4R** : 4 relays board
- **CETHE** : Ethernet network board
- **HRP** : high resolution (example in pressure : 0.1 Pa) with SPI2-100 board
- **Calibration certificate**

www.sazehgostarsgp.com

@sazehgostar_paytakht

www.kimo.fr

Distributed by :



EXPORT DEPARTMENT
Tel : + 33. 1. 60. 06. 69. 25 - Fax : + 33. 1. 60. 06. 69. 29
e-mail : export@kimo.fr